



SUBMITTAL SHEET

Product(s): Trim-Tex Wall Fast Cap for 2 1/2" Metal Studs

Description: Trim-Tex Wall Fast Cap is designed to be used with 2 1/2" metal studs and is an easy application you can use to finish door ways, wall ends, kneewalls, and closets.

Advantages: Fast Cap eliminates the need for 2 corner beads and drywall on the face. Made from rust proof, dent resistant PVC to reduce jobsite and handling damage. Does not contain cellulose, a potential food source for mold

Limitations: Product is designed for interior use.

Applicable Standards: Rigid PVC products made by Trim-Tex meet ASTM specifications D3678-97, D1784-03, C1047-99.

Surface Characteristics: Trim-Tex products are made from PVC. PVC does not support combustion and is self extinguishing when the source of flame or heat is removed.

Installation: First dry fit and cut your piece to length. Liberally apply 2 beads of drywall stud adhesive or equivalent to the studs you will lay the Fast Cap over. For ultimate bond spray a coat of 847 on the mud legs and the drywall. Install the Fast Cap immediately and pressure the mud legs to the drywall. If the adhesive dries and there is no tack to it, apply additional coats of spray adhesive. Once in position, staple the mud legs into place every 6"-8" with 1/2" long divergent staples. A combination of 847 Spray Adhesive and staples is the preferred method of installation.

Finishing: To improve the bondability of drywall compounds, textures & plaster products to any bead, use MUD-MAX Drywall Compound Additive. Priming is not required. Always use a high quality paint.

Accessories: North by Honeywell - Safety Products distributed by Trim-Tex.

Job Name _____

Contractor _____ Date _____

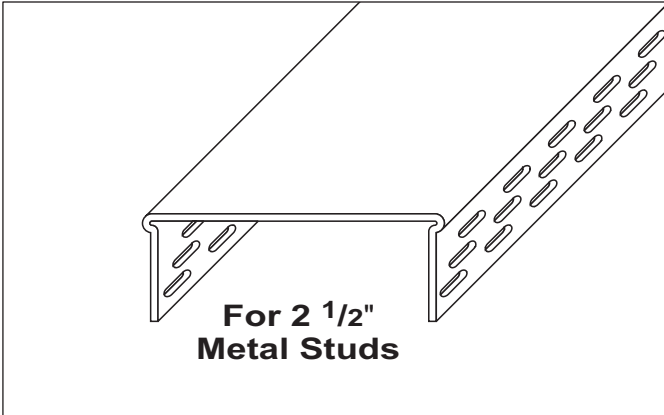

Available in two widths:

3 1/2" Fast Cap for 2 1/2" metal studs and 2 pieces of 1/2" drywall.
3 3/4" Fast Cap for 2 1/2" metal studs and 2 pieces of 5/8" drywall.

STOCK NUMBER	SIZE	LENGTH	PCS PER BOX
4883	3 1/2"	10'	10
4810	3 3/4"	10'	10

Approvals (Signatures or Stamps)